

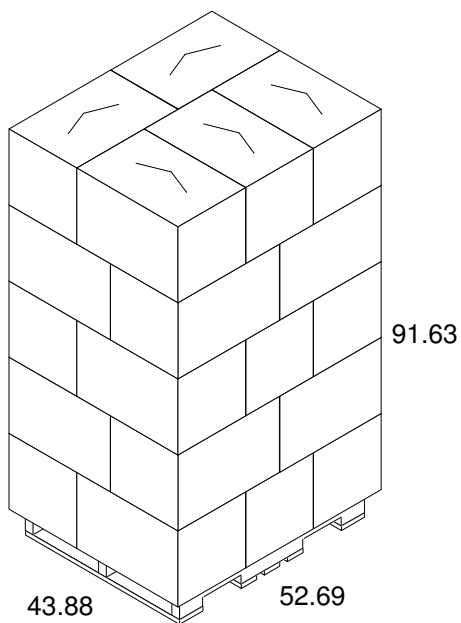

SBT500

Date Printed : 12/27/2017
Last Saved : 9/7/2017

Tops Engineering



53 FT. Dry Van 630.0x98.0x110.0				
	Shipper (ID)	Shipper (OD)	UnitLoad (Incl. Pal)	Vehicle Load
Ln:	26.000 in	26.313 in	52.69 in	623.44 in
Wd:	17.250 in	17.563 in	43.88 in	96.6 in
Ht:	16.500 in	17.125 in	91.63 in	91.6 in
Net:		0.00 lb	0.00 lb	0.00 lb
Grs:		0.00 lb	65.00 lb	1690.00 lb
Cube:	4.283 ft3	4.580 ft3	122.573 ft3	33192.067 ft3
		Height Vert		
Shipper:			25	650
UnitLoads:				26
Area Efficiency:		0.00 %	120.34 %	97.35 %
Cubic Efficiency:		0.00 %	114.49 %	81.09 %
Cases per layer:			5	650
UL per layer:				26
Layers/load:			5	1
Pattern:			Interlock	Pinwheel
RSC Area:		21.14 ft2	528 ft2	13739 ft2
Density (gr/cc):			0.0000	0.0000

GMA (Notched) 48.00x40.00x6.00

	Shipper (ID)	Shipper (OD)	UnitLoad (Incl. Pal)	Vehicle Load
Ln:	26.000 in	26.313 in	52.69 in	623.44 in
Wd:	17.250 in	17.563 in	43.88 in	96.6 in
Ht:	16.500 in	17.125 in	91.63 in	91.6 in
Net:		0.00 lb	0.00 lb	0.00 lb
Grs:		0.00 lb	65.00 lb	1690.00 lb
Cube:	4.283 ft3	4.580 ft3	122.573 ft3	33192.067 ft3
		Height Vert		
Shipper:			25	650
UnitLoads:				26
Area Efficiency:		0.00 %	120.34 %	97.35 %
Cubic Efficiency:		0.00 %	114.49 %	81.09 %
Cases per layer:			5	650
UL per layer:				26
Layers/load:			5	1
Pattern:			Interlock	Pinwheel
RSC Area:		21.14 ft2	528 ft2	13739 ft2
Density (gr/cc):			0.0000	0.0000

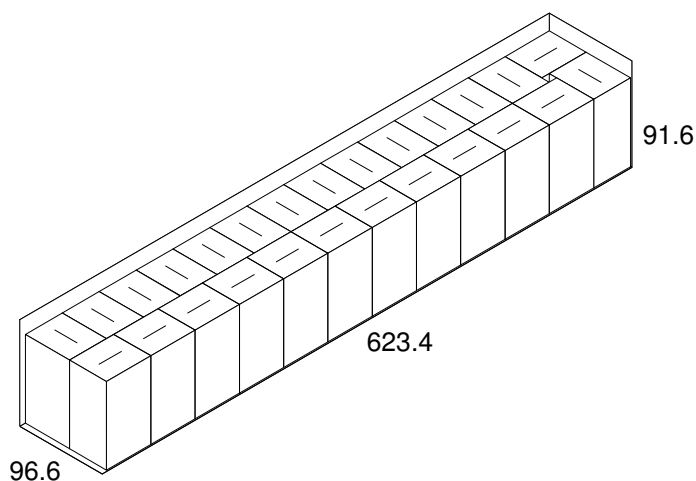

Notes: